

Window head

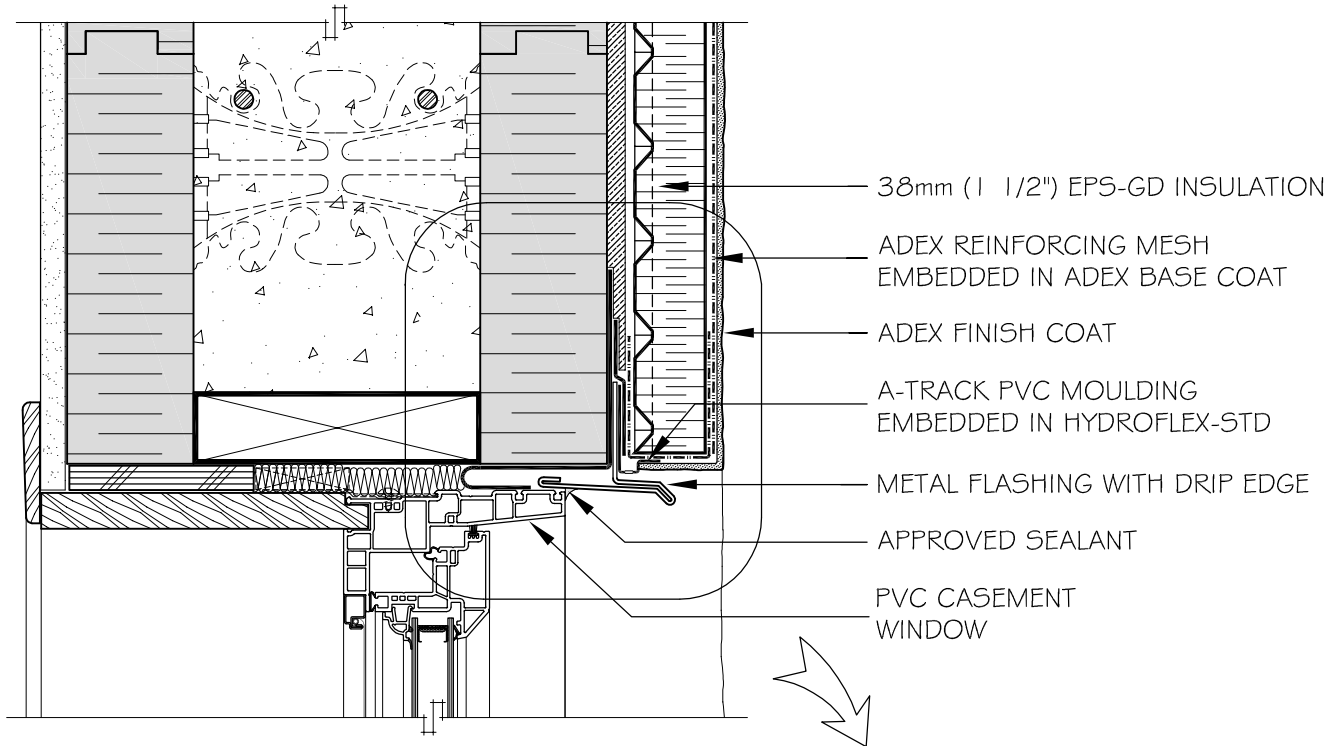

HYDROFLEX-STD MEMBRANE / ADHESIVE

A-FLEX TAPE

ADEX STARTER MESH EMBEDDED IN BASE COAT AROUND ALL EDGES ONTO THE BACKSIDE OF THE INSULATION (BACKWRAPPING)

A-FLEX TAPE TO BE SEALED TO THE FRAME

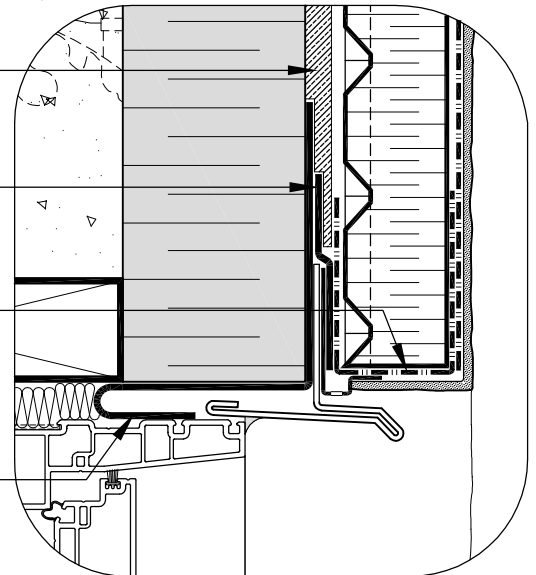

DRAWINGS ARE NOT TO SCALE

This document contains the applicable recommendations for the installation of the adexRES-ICF system. They are provided solely for indicative purposes and are subject to changes without notice. Adex Systems Inc. reserves the right to make any eventual changes in keeping with technological advances. The professional (specialised designer, architect, engineer or any other professional) that decides to use this information, in any way, assumes full responsibility, whether direct or indirect, of the outcomes of this usage. Adex Systems Inc. will not assume or incur any responsibility that could have led to damages, defects, faultiness, deficiencies, prejudices, losses or decrease of profit, that they be direct or indirect, resulting from the Professional's use of the product. The use of this product by an unqualified person is strongly advised against.