

- 1 EIFS TAPE & PRIMER
- 2 HYDROFLEX WATER RESISTIVE BARRIER (WRB)
- 3 ADEX ADHESIVE
- 4 GD-CONTOUR BOARD
- 5 EPS-GD INSULATION
- 6 ADEX BASECOAT
- 7 STANDARD MESH
- 8 PRIMEX PRIMER
- 9 FINISH COAT

## Description

The adex-**RS** system is a water-managed exterior insulation and finish system that has been favourably evaluated by CCMC (12913-R) including use over wood substrates. The system incorporates a secondary water resistant barrier (WRB), a vertical drainage plane, and a geometrically designed EPS board with 10mm grooves. The adex-**RS** system is in full compliance with CAN/ULC-S716.1 "Exterior Insulation and Finish Systems (EIFS) - Materials and Systems."

THE adex-RS SYSTEM, OR ITS MAJOR COMPONENTS MEET THE FOLLOWING NON-COMBUSTIBILITY STANDARDS:

**CAN/ULC S134** : Fire Test of Exterior Wall Assemblies;

**CAN/ULC S114** : Method of Test for Determination of Non-Combustibility in Building Materials;

**CAN/ULC S101** : Fire Endurance Tests of Building Construction and Materials.

## Benefits

- Provides continuous insulation (CI); reduces energy use
- Seals the building envelope and ensures seamless protection of the substrate
- Allows for drainage of incidental moisture
- Lightweight, durable, and flexible
- Architectural design flexibility
- Resists dirt, fading, and abrasion
- Non-combustible rated as per the National Building Code

## Features

- EPS-GD insulation
- Vertical ribbon fastening
- Seamless substrate protection
- Non-combustible basecoat
- CCMC evaluated (12913-R) including for use over wood substrates
- Dual barrier
- Unlimited colour selection
- Compliant with CAN/ULC-S716.1

Please refer to [adex.ca](http://adex.ca) for the latest version of this document, specifications (PDF + Word), technical drawings, product technical sheets, warranties, maintenance guide...and much more.

This document contains information made available to specialised designers, architects, engineers or other professionals, as a guide only, to help them prepare a technical specification. Specialised designers, architects, engineers or other professionals bear the complete responsibility of evaluating usability, conformity and relevance of the information in view of the particular project and they commit to verify all technical data in the present document in order to assess their suitability in the project. When such use is done by specialised designers, architects, engineers or other professionals, they take full responsibility for the information as if it were their own. Use by a non-specialised person is strongly advised against.

## PART 1 GENERAL

### 1.1 RELATED SECTIONS

1. Section 01 40 00: Quality Requirements
2. Section 03 11 00: Concrete Forming
3. Section 03 30 00: Cast-in-Place Concrete
4. Section 04 20 00: Unit Masonry
5. Section 05 40 00: Cold-Formed Metal Framing
6. Section 06 10 00: Rough Carpentry
7. Section 07 20 00: Thermal Protection
8. Section 07 25 00: Weather Barriers (Vapour / Air Barriers)
9. Section 07 60 00: Flashing and Sheet Metal
10. Section 07 90 00: Joint Protection
11. Section 08 00 00: Openings
12. Section 09 28 00: Backing Boards and Underlayments
13. Section 09 90 00: Painting and Coating

### 1.2 DESCRIPTION

- 1.2.1 The adex-**RS** is an Exterior Insulation and Finish System (EIFS) composed of a continuous water resistive barrier (air and/or vapour barrier) installed over an approved substrate, a 10mm deep geometrically-designed EPS board providing an effective thermal insulation and drainage plane, adhesive for attachment of insulation board, glass fibre reinforcement mesh embedded in a non-combustible acrylic basecoat on the insulation board face, an acrylic primer and finish coat as defined by CAN/ULC S716.1-09.
- 1.2.2 The adex-**RS** assembly has been favourably evaluated by the Canadian Construction Materials Centre (CCMC) as described in the evaluation report #12913-R.
- 1.2.3 The adex-**RS** system or its major components meet the National Building Code non-combustibility requirements of Articles 3.1.5.5, 3.2.3.7 and 3.2.3.8 for commercial and high rise construction projects due to the favourable evaluation reports listed below:

- 1.2.3.1 CAN/ULC S134: Fire Test of Exterior Wall Assemblies;
  - 1.2.3.2 1.2.3.2 CAN/ULC S114: Method for Determination of Non-Combustibility;
  - 1.2.3.3 CAN/ULC S101: Fire Endurance Tests of Building Construction and Materials.
- 1.2.4 The adex-**RS** system is in full compliance with CAN/ULC-S716.1 "Exterior Insulation and Finish Systems (EIFS) - Materials and Systems".

### 1.3 REFERENCE STANDARDS

- 1.3.1 ASTM International
  - 1.3.1.1 ASTM B117: Standard Practice for Operating Salt Spray (Fog) Apparatus;
  - 1.3.1.2 ASTM C203: Standard Test Methods for Breaking Load and Flexural Properties of Block-Type Thermal Insulation;
  - 1.3.1.3 ASTM C518: Standard Test Method for Steady-State Thermal Transmission Properties by Means of the Heat Flow Meter Apparatus;
  - 1.3.1.4 ASTM C666: Standard Test Method for Resistance of Concrete to Rapid Freezing and Thawing;
  - 1.3.1.5 ASTM D522: Standard Test Methods for Mandrel Bend Test of Attached Organic Coatings;
  - 1.3.1.6 ASTM D523: Standard Test Method for Specular Gloss;
  - 1.3.1.7 ASTM D570: Standard Test Method for Water Absorption of Plastics;
  - 1.3.1.8 ASTM D822: Standard Practice for Filtered Open-Flame Carbon-Arc Exposures of Paint and Related Coatings;
  - 1.3.1.9 ASTM D1621: Standard Test Method for Compressive Properties Of Rigid Cellular Plastics;
  - 1.3.1.10 ASTM D1623: Standard Test Method for Tensile and Tensile Adhesion Properties of Rigid Cellular Plastics;
  - 1.3.1.11 ASTM D1784: Standard Specification for Rigid Poly(Vinyl Chloride) (PVC) Compounds and Chlorinated Poly(Vinyl Chloride) (CPVC) Compounds;

- 1.3.1.12 ASTM D2126: Standard Test Method for Response of Rigid Cellular Plastics to Thermal and Humid Aging;
- 1.3.1.13 ASTM D2370: Standard Test Method for Tensile Properties of Organic Coatings;
- 1.3.1.14 ASTM D2523: Standard Practice for Testing Load-Strain Properties of Roofing Membranes;
- 1.3.1.15 ASTM D2842: Standard Test Method for Water Absorption of Rigid Cellular Plastics;
- 1.3.1.16 ASTM D4541: Standard Test Method for Pull-Off Strength of Coatings Using Portable Adhesion Testers;
- 1.3.1.17 ASTM D5034: Standard Test Method for Breaking Strength and Elongation of Textile Fabrics (Grab Test);
- 1.3.1.18 ASTM D5420: Standard Test Method for Impact Resistance of Flat, Rigid Plastic Specimen by Means of a Striker Impacted by a Falling Weight (Gardner Impact);
- 1.3.1.19 ASTM E96: Standard Test Methods for Water Vapor Transmission of Materials;
- 1.3.1.20 ASTM E283: Standard Test Method for Determining Rate of Air Leakage Through Exterior Windows, Curtain Walls, and Doors Under Specified Pressure Differences Across the Specimen;
- 1.3.1.21 ASTM E330: Standard Test Method for Structural Performance of Exterior Windows, Doors, Skylights and Curtain Walls by Uniform Static Air Pressure Difference;
- 1.3.1.22 ASTM E331: Standard Test Method for Water Penetration of Exterior Windows, Skylights, Doors, and Curtain Walls by Uniform Static Air Pressure Difference;
- 1.3.1.23 ASTM E1131: Standard Test Method for Compositional Analysis by Thermogravimetry;
- 1.3.1.24 ASTM E1252: Standard Practice for General Techniques for Obtaining Infrared Spectra for Qualitative Analysis;
- 1.3.1.25 ASTM E2098: Standard Test Method for Determining Tensile Breaking Strength of Glass Fiber Reinforcing Mesh for Use in Class PB Exterior Insulation and Finish Systems (EIFS), after Exposure to a Sodium Hydroxide Solution;
- 1.3.1.26 ASTM G 155: Standard Practice for Operating-Xenon Arc Light Apparatus, for Exposure of Non-metallic Materials.
- 1.3.2 CSA International
  - 1.3.2.1 CAN/CSA A3000: Cementitious materials compendium (Consists of A3001, A3002, A3003, A3004 and A3005).
  - 1.3.3 National Research Council of Canada (NRC)
    - 1.3.3.1 Canadian Construction Materials Centre (CCMC): Technical Guide for EIFS.
  - 1.3.4 Underwriters' Laboratories of Canada (ULC)
    - 1.3.4.1 1CAN/ULC S101: Fire Endurance Tests of Building Construction and Materials;
    - 1.3.4.2 CAN/ULC S102: Surface Burning Characteristics of Building Materials and Assemblies;
    - 1.3.4.3 CAN/ULC S114: Method for Determination of Non-Combustibility;
    - 1.3.4.4 CAN/ULC S134: Fire Test of Exterior Wall Assemblies;
    - 1.3.4.5 CAN/ULC S701: Standard for Thermal Insulation, Polystyrene, Boards and Pipe Covering;
    - 1.3.4.6 CAN/ULC S716.1: Standard for Exterior Insulation and Finish Systems (EIFS) - Materials and Systems;
    - 1.3.4.7 CAN/ULC S716.2: Standard for Exterior Insulation and Finish Systems (EIFS) - Installation of EIFS components and Water Resistive Barrier;
    - 1.3.4.8 CAN/ULC S716.3: Standard for Exterior Insulation and Finish Systems (EIFS) - Design Application.
- 1.4 DESIGN REQUIREMENTS
  - 1.4.1 All work must comply with CCMC requirements as outlined in its evaluation report #12913-R.
  - 1.4.2 All work undertaken must comply with the current codes and norms, best practice guides, as well as the manufacturer's installation instructions.
  - 1.4.3 The substrate shall be engineered to withstand all applicable loads, including live, dead, seismic, suction, etc..
  - 1.4.4 On horizontal surfaces, the minimum slope of the system shall be a 6:12 pitch with a maximum length of 250mm (10").
  - 1.4.5 The substrate shall be protected with a waterproofing membrane sealed at all joints and openings.
  - 1.4.6 The substrate shall be one of the following:
    - a) Brick, masonry or concrete;
    - b) Insulated concrete forming (ICF);
    - c) Fibre cement board;
    - d) Glass-mat faced gypsum board;
    - e) Plywood or OSB board.
  - 1.4.7 Expansion joints that allow for natural

building movement shall be installed in the following locations:

- 1.4.7.1 At expansion joints that occur in the substrate;
  - 1.4.7.2 At any abutment of the system with other materials;
  - 1.4.7.3 Where the substrate changes;
  - 1.4.7.4 Where significant structural movement occurs;
  - 1.4.7.5 At a maximal distance of 10m (30ft), to counter thermal expansion;
  - 1.4.7.6 Where deflections that might be in excess of L/240 are expected;
  - 1.4.7.7 At the floor line in wood frame construction (may not be required when using engineered wood beams).
- 1.4.8 Expansion joints, or fire-breaks, shall extend through the EIFS and shall include proper flashing attached to the substrate (horizontal joints).

## 1.5 QUALITY ASSURANCE

- 1.5.1 Manufacturers
  - 1.5.1.1 EIFS manufacturer shall be Adex Systems Inc.
  - 1.5.1.2 Be a member of and in good standing with the EIFS Council of Canada.
  - 1.5.1.3 All other third-party material manufacturers shall be recognized by Adex Systems Inc.
- 1.5.2 Applicators
  - 1.5.2.1 Applicators shall have the necessary permits.
  - 1.5.2.2 Applicator shall have a minimum of (2) two-years of experience in applying EIF systems and employ sufficient, knowledgeable personnel to complete work on schedule.
  - 1.5.2.3 Applicator shall follow all EIFS manufacturer's directions when installing system components.

## 1.6 DELIVERY & STORAGE

- 1.6.1 Deliver materials to the job site in their original unopened packages, clearly marked with the manufacturer's name, and description of contents.
- 1.6.2 Store in a clean, dry, well-ventilated area at a temperature not less than 5°C (41°F).
- 1.6.3 Protect materials from the elements of weather, and keep away from excessive heat (temperatures above 32°C (90°F)).

## 1.7 ARCHITECTURAL SAMPLES

- 1.7.1 Upon request, Adex or its distributor will provide a minimum 200mm x 200mm (8"x8") sample for colour and texture approval.

- 1.7.2 Do not start any final work until the Consultant gives final approval of sample(s).

## 1.8 JOB MOCK-UP

- 1.8.1 Construct a mock-up panel on site as part of the actual wall on an area as indicated by the Consultant. The approved mock-up panel shall form a standard for the project and no work of inferior quality will be accepted. The mock-up shall match sample panel(s) submitted to the Consultant as described in paragraph 1.7 of this Section.

**SPEC NOTE: A job mock up of the assembly is highly recommended on every project to meet expectations and intended performance.**

## 1.9 JOB CONDITIONS

- 1.9.1 Ambient and surface temperatures shall be minimum 5°C (41°F) during installation.
- 1.9.2 When installing in climatic temperatures below 5°C (41°F), tarping, heating and ventilation shall be provided to maintain proper installation temperatures.
- 1.9.3 Ambient temperature shall be maintained above 5°C (41°F) for a minimum of 24 hours after installation to ensure that drying is complete. Allow for extended drying times in cool, higher humidity conditions.
- 1.9.4 Installation of Adex materials shall be co-ordinated with other construction trades.

## 1.10 ALTERNATIVES

- 1.10.1 Systems considered equivalent to adex-**RS** shall be evaluated by CCMC according to Master Format #07 24 13.01, and shall be approved by the architect, in writing, at least ten (10) working days prior to the project bid date.

## 1.11 WARRANTY

- 1.11.1 Upon request, the manufacturer shall provide a (10) ten-year limited warranty, stating that materials conform to specifications and are free of manufacturing defects.

## PART 2 PRODUCTS

### 2.1 MANUFACTURER

2.1.1 All components of the adex-**RS** system shall be obtained from Adex Systems Inc. or its authorised distributors. No substitution or addition of other material is permitted without written consent from the manufacturer.

### 2.2 PRODUCTS

#### 2.2.1 Water Resistive Barrier

2.2.1.1 Shall be 100% acrylic, such as

- a) Vapour permeable membranes:
  - HYDROFLEX STD mixed 1:1 by weight with Type GU cement or;
  - HYDROFLEX WO or;
- b) Vapour barrier membranes:
  - HYDROFLEX-GUARD, mixed 1:1 by weight with Type GU cement or;
  - HYDROFLEX VB.

2.2.1.2 Shall meet ASTM E-283 for air permeability;

2.2.1.3 Shall be supplied by Adex Systems Inc.

**SPEC NOTE: Design and location of all air and vapour barriers is the responsibility of the Design Professional.**

#### 2.2.2 GD-Contour Board

2.2.2.1 Shall be made by a manufacturer approved by Adex Systems Inc. Please contact your Adex representative to select the appropriate EPS Board design.

2.2.2.2 Shall conform to CAN-ULC S701.1: 2017, Type 1 and Type 2 and be made from virgin material with a nominal density of 16 Kg/m<sup>3</sup> (1 Lb/ft<sup>3</sup>) and 24 Kg/m<sup>3</sup> (1.5 Lb/ft<sup>3</sup>).

2.2.2.3 Shall be geometrically grooved to a 10mm minimum depth.

2.2.2.4 Minimum board thickness shall be 50mm (2").

2.2.2.5 Shall be supplied by Adex Systems Inc.

#### 2.2.3 Adhesive

2.2.3.1 Shall be a 100%-acrylic polymer based material.

2.2.3.2 ADEX BASECOAT mixed with an approximately equal weight of Type GU Portland cement (weight ratio is 1:1).

2.2.3.3 Adhesive shall be applied onto the approved membrane on the wall when using ADEX EPS-GD INSULATION using a 3/8"x1/2"x1-1/2" U-notched trowel (typical).

#### 2.2.4 Insulation Board

#### 2.2.4.1 ADEX EPS-GD INSULATION

made by a manufacturer approved by Adex Systems Inc. Please contact your Adex representative to select the appropriate EPS Board design.

2.2.4.2 Shall conform to CAN-ULC S701.1: 2017, Type 1 and Type 2 and be made from virgin material with a nominal density of 16 Kg/m<sup>3</sup> (1 Lb/ft<sup>3</sup>) and 24 Kg/m<sup>3</sup> (1.5 Lb/ft<sup>3</sup>).

2.2.4.3 Shall be grooved at the back with 10mm deep grooves according to specifications of Adex Systems Inc.

2.2.4.4 ADEX EPS-GD INSULATION minimum board thickness shall be 50mm (2") and maximum board size shall be 600mm x 1200mm (24" x 48").

2.2.4.5 Shall be sold by Adex Systems Inc. or by one of its authorised distributors.

#### 2.2.5 Non-Combustible Basecoat

2.2.5.1 Shall be a 100% acrylic-based, asbestos-free product, manufactured by Adex Systems Inc. such as ADEX BASECOAT or DRYMIX basecoat.

2.2.5.2 ADEX BASECOAT mixed with an approximately equal weight of Type GU Portland cement (Weight ratio = 1:1).

2.2.5.3 DRYMIX basecoat mixed with approximately 6 litres of clean water in a clean container.

2.2.5.4 Shall conform to CAN/ULC-S114: Standard Method of Test for Determination of Non-Combustibility in Building Materials.

#### 2.2.6 Reinforcing Fibreglass Mesh

2.2.6.1 Shall be purchased from Adex Systems Inc. or from one of its authorised distributors.

2.2.6.2 Shall meet ASTM D-5034 standards.

2.2.6.3 Shall have different weights according to specific needs:

- a) QUICK TAPE MESH:  
65g/m<sup>2</sup> (2 oz/yd<sup>2</sup>)
- b) STARTER MESH:  
150g/m<sup>2</sup> (4.5 oz/yd<sup>2</sup>)
- c) STANDARD MESH (DESIGN):  
150g/m<sup>2</sup> (4.7 oz/yd<sup>2</sup>)
- d) STANDARD MESH PLUS:  
190g/m<sup>2</sup> (6 oz/yd<sup>2</sup>)
- e) INTERMEDIATE MESH:  
375g/m<sup>2</sup> (11 oz/yd<sup>2</sup>)
- f) ARMOUR MESH:  
500g/m<sup>2</sup> (15 oz/yd<sup>2</sup>)
- g) CORNER MESH:  
305g/m<sup>2</sup> (9 oz/yd<sup>2</sup>)

#### 2.2.7 Point-Impact Resistant Basecoat

**(OPTIONAL)**

**2.2.7.1** For geographic locations prone to nesting and migration of bird-pecking species, such as woodpeckers and/or flickers, a point-impact resistant basecoat layer is highly recommended.

**2.2.7.2** Shall be a 100% acrylic polymer-based product, reinforced with graphene and manufactured by Adex Systems Inc, such as Adex GRAPHEXCOAT.

**2.2.7.3** GRAPHEXCOAT is mixed with an approximately equal weight of Type GU Portland cement (Weight ratio = 1:1) and up to 1-Litre of water.

**2.2.7.4** GRAPHEXCOAT shall be installed after the Reinforcing Mesh is embedded into the basecoat layer.

**2.2.7.5** Shall be listed in the manufacturer's current fire testing: CAN/ULC-S134-13 "Standard Method of Fire Test of Exterior Wall Assemblies"

**2.2.8 Primer**

**2.2.8.1** Shall be a tinted, acrylic-based, roll-on priming agent, such as PRIMEX PRIMER, manufactured by Adex Systems Inc. PRIMEX PRIMER is not mandatory but highly recommended as it will enhance the depth of colour, increase the yield of finish coat, and enhance the longevity of the finish coat.

**2.2.9 Finish Coat**

**2.2.9.1** Shall be a factory-mixed, 100% acrylic-based Adex Finish Coat, containing integral colour and texture.

**2.2.9.2** The texture shall be [See the Adex Specification Binder or visit [www.adex.ca](http://www.adex.ca) to view the various textures].

**2.3 OTHER MATERIALS**

**2.3.1 Portland Cement**

**2.3.1.1** Shall be lump-free, Type GU (Type 10) Portland cement conforming to CSA-A3001 standards.

**2.3.2 Water**

**2.3.2.1** Shall be clean, potable, and free of sediment.

**2.3.3 Mechanical Fasteners**

**2.3.3.1** Shall be Wind-Lock Wind-Devil II or ULP-302 low-profile, high-density polypropylene washers.

**2.3.3.2** Screws must be galvanized or have an approved corrosion-resistant coating with thread patterns and tips designed to fasten into steel or wood studs, or masonry substrates.

**2.3.4 Transition Membrane**

**2.3.4.1** Shall be a flexible, self-adhesive composite material tested for adhesion to itself and to Adex components. Suitable Adex materials include HYDROFLEX FLASH, A-FLEX SEALANT AND MESH, Adex Primerless EIFS TAPE (4"-12" rolls), or Adex EIFS TAPE (4"-12" rolls) used with the appropriate primer.

**2.3.5 PVC trims (if necessary):**

**2.3.5.1** Shall meet ASTM-D1784 standards for exterior use.

**2.3.6 Backer Rod & Sealant**

**2.3.6.1** Refer to Section 07 90 00.

**2.3.6.2** Backer rod must be closed pore type.

**2.3.6.3** Use only low-modulus caulking with long service lives and compatible with EIFS components and adjacent surfaces.

**2.3.6.4** Products should meet ASTM C1382: Standard Test Method for Determining Tensile Adhesion Properties of Sealants When Used in EIFS Joints, such as: ADSEAL DWS 4580 or LM4600 by ADFAST

**2.4 TESTS**

**2.4.1** Tests performed by an independent laboratory on the specified materials can be requested.

**2.4.1.1** Properties shall meet or exceed the following values when tested by the methods listed:

**TEST METHOD**

**FIRE TEST OF EXTERIOR WALL ASSEMBLIES CAN/ULC-S134**

Pass

**FIRE ENDURANCE TESTS OF BUILDING CONSTRUCTION AND MATERIALS: CAN/ULC-S101**

The adex-**RS** system assembly, with 5 inch insulation boards, stayed in place for the 15 minute fire test.

**DURABILITY UNDER ENVIRONMENTAL CYCLIC CONDITIONS:**

- CCMC Technical Guide 8.1.3 (60 Cycles)

No cracking, blistering, sagging of basecoat. No detachment or crazing of finish coat.

**ACCELERATED WEATHER RESISTANCE:**

- CCMC Technical Guide 8.1.2.3.6; ASTM G155 (Exposed 2000 Hours)

No cracking, flaking, or deleterious effects.
<b>SALT SPRAY RESISTANCE:</b> • ASTM-B117-16 (Exposed 300 Hours)
No cracking, flaking, or deleterious effects.
<b>MILDEW AND FUNGUS RESISTANCE:</b> • CCMC Technical Guide 8.1.2.5.5
No mildew or fungal growth.
<b>IMPERMEABILITY TO WATER:</b> • CCMC Technical Guide 8.1.2.5.3
Pass. No water penetration in less than 2 hrs.
<b>WATER ABSORPTION:</b> • CCMC Technical Guide 8.1.2.5.4
Pass. ≤ 20 %.
<b>ADHESION BOND TEST:</b> • CCMC Technical Guide 8.1.2.3.1 (WRB) and 8.1.2.4.1 (EPS ADHESIVE)
Pass.
<b>ADHESION BOND TEST:</b> • CCMC Technical Guide 8.1.3.1 (LAMINA)
Pass.
<b>IMPACT RESISTANCE:</b> • CCMC Technical Guide 8.1.3.2 (ASTM D5420-16)
Pass.
<b>JOINT DISRUPTION RESISTANCE:</b> • CCMC Technical Guide 8.1.2.3.3
Pass.
<b>WIND LOAD RESISTANCE:</b> • CCMC Technical Guide 8.1.3.4 (ASTM E330M-14)
Pass.

■ Test Method  
■ Result

## PART 3 EXECUTION

### 3.1 INSPECTION

- 3.1.1 Inspect the substrate to verify that it is structurally sound and solid, ensuring there are no irregular voids or projections.
- 3.1.2 Inspect all metal flashing to ensure that they are properly installed, making certain that moisture will be deflected to the exterior of the system.

- 3.1.3 The architect and general contractor shall be advised of any discrepancies. Work shall not proceed until unsatisfactory conditions are corrected.

### 3.2 PREPARATION

- 3.2.1 Ensure conduit pipes, cables and outlets are adequately covered before commencing with installation.
- 3.2.2 Adjacent finish work (such as brick, siding, concrete, etc.) must be protected from damage during the installation of Adex materials.

### 3.3 MIXING

- 3.3.1 HYDROFLEX STD membrane
  - 3.3.1.1 Mix the contents of the HYDROFLEX pail until thoroughly blended. This will remove any settling of the contents due to storage.
  - 3.3.1.2 In a clean container, mix HYDROFLEX and Type GU Portland cement at a ratio (by weight) of one-to-one. Add Portland cement in small increments to prevent lumps from occurring.
  - 3.3.1.3 Allow mixture to set up for 5 minutes and mix again to break the initial set.
  - 3.3.1.4 Small amounts of water may be added to adjust the consistency. All other additives (such as rapid binder, anti-freeze, accelerator or others) are strictly prohibited.
- 3.3.2 HYDROFLEX GUARD membrane
  - 3.3.2.1 Mix the contents of the HYDROFLEX pail until thoroughly blended. This will remove any settling of the contents due to storage.
  - 3.3.2.2 In a clean container, mix HYDROFLEX and Type GU Portland cement at a ratio (by weight) of one-to-one. Add Portland cement in small increments to prevent lumps from occurring.
  - 3.3.2.3 Allow mixture to set up for 5 minutes and mix again to break the initial set.
  - 3.3.2.4 Small amounts of water may be added to adjust the consistency. All other additives (such as rapid binder, anti-freeze, accelerator or others) are strictly prohibited.

### 3.3.3 ADEX BASECOAT

- 3.3.3.1 Mix the contents of the Adex BASECOAT pail until thoroughly blended. This will remove any settling of the contents due to storage.
- 3.3.3.2 In a clean container, combine Adex BASECOAT with fresh, lump-free Type GU Portland cement at a ratio

of 1:1 by weight. Thoroughly mix to a homogenous state using a paddle mixer and electric drill. Add Portland cement in small increments to prevent lumps from occurring.

**3.3.3.3** Allow mixture to set up for 5 minutes, then mix again to break the initial set.

**3.3.3.4** Small amounts of clean water may be added to adjust the consistency and workability. All other additives (antifreeze, accelerators, or otherwise) are strictly forbidden

### **3.3.4 ADEX DRYMIX**

**3.3.4.1** In a clean container, mix ADEX DRYMIX basecoat with approximately 6 litres of water.

**3.3.4.2** Thoroughly mix to a homogeneous state. Allow mixture to set up for 5 minutes and mix again to break the initial set.

**3.3.4.3** Small amounts of clean water may be added to adjust the consistency and workability. All other additives (antifreeze, accelerators, or otherwise) are strictly forbidden

### **3.3.5 GRAPHEXCOAT point-impact resistant basecoat (Optional)**

**3.3.5.1** Mix the contents of the GRAPHEXCOAT-A or GRAPHEXCOAT-B pails until thoroughly blended. This will remove any settling of the contents due to storage.

**3.3.5.2** For ease of mixing, split the pail of GRAPHEXCOAT-A or GRAPHEXCOAT-B into two (2) equal portions. Use only clean containers for mixing.

**3.3.5.3** In a clean container, combine GRAPHEXCOAT-A or GRAPHEXCOAT-B with fresh, lump-free Type GU Portland cement at a ratio of 1:1 by weight. Thoroughly mix to a homogenous state using a paddle mixer and electric drill. Add Portland cement in small increments to prevent lumps from occurring.

**3.3.5.4** Allow mixture to set up for 5 minutes, then mix again to break the initial set.

**3.3.5.5** Up to 1-Litre of potable water may be added to adjust the consistency. All other additives (antifreeze, accelerators, or otherwise) are strictly forbidden. Do not overwater.

**SPEC NOTE:** Refer to the Adex website, [www.adex.ca](http://www.adex.ca), for individual product Technical Bulletins displaying additional mixing and installation instructions.

## **3.4 INSTALLATION**

### **3.4.1 Flashing**

**3.4.1.1** Refer to Section 07 60 00, Flashing.

**3.4.1.2** Ensure flashing is installed where specified on the construction documents. Flashing must be installed at through-wall breaks, at the baseline of walls, and anywhere else the system is to drain to the exterior.

**3.4.1.3** Apply approved transition membrane over the flashing leg and apply the trowel-on membrane directly to the membrane surface.

### **3.4.2 Sheathing Joint Treatment**

**3.4.2.1** Complete sheathing joint treatments as per the Water Resistive Barrier (WRB) data sheets.

### **3.4.3 Water Resistive Barrier**

**3.4.3.1** Ensure transition membranes (HYDROFLEX FLASH, A-FLEX SEALANT & MESH, Primerless EIFS TAPE, or Adex EIFS TAPE) are installed, sealing all junctions between the substrate and other materials (wall penetrations, openings, and dissimilar materials).

**3.4.3.2** The Water Resistive Barrier (WRB) shall be joined to other components of the system so that the air barrier is continuous in three dimensions.

**3.4.3.3** Read the Water Resistive Barrier data sheets for complete installation instructions.

**3.4.3.4** Two-coat applications are required over oriented strand board (OSB) substrates.

**3.4.3.5** HYDROFLEX STD, HYDROFLEX WO, or HYDROFLEX VB:

a) Ensure flexible membranes are installed, sealing all junctions between the substrate and other materials (openings, wall penetrations, etc.).

b) Apply a layer of HYDROFLEX membrane over all sheathing joints and immediately embed STARTER/DETAIL MESH into the membrane.

c) Apply HYDROFLEX membrane over the entire surface ensuring a minimal thickness of 1.6mm (1/16").

**3.4.3.6** HYDROFLEX GUARD membrane:

a) STANDARD MESH is embedded into the HYDROFLEX GUARD membrane to help dictate proper thickness as well as treat the sheathing joints.

b) Trowel HYDROFLEX GUARD over the substrate to an approximate thickness of 2mm (3/16").

- c) Immediately embed the STANDARD MESH into the wet HYDROFLEX GUARD membrane. Trowel from the centre of the mesh outwards to prevent wrinkles from forming in the mesh. Smooth out the membrane to eliminate trowel lines.
  - d) The final thickness of the HYDROFLEX GUARD membrane shall be such that the STANDARD MESH is fully embedded and not visible. If mesh is visible, apply an additional skim coat of HYDROFLEX GUARD.
- 3.4.3.7** Allow the Water Resistive Barrier (WRB) to fully cure before adhering insulation boards over the membrane.
- 3.4.3.8** **NOTE:** HYDROFLEX STD and membrane applied at a thickness of 2.2 mm may serve as both second coat membrane and adhesive, as long as they are installed over a first coat of membrane. The EPS-GD insulation must be installed immediately after the membrane is applied.
- 3.4.4** Stay-In-Place Mechanism
- 3.4.4.1** At the top of wall sections, STARTER MESH shall be adhered to the Water Resistive Barrier (min. 100mm (4")) with ADEX BASECOAT. The mesh will be wrapped to the front face of the EPS insulation board during the wall mesh application. This will create a "stay-in-place" mechanism.
- 3.4.4.2** Required for projects needing to meet CAN/ULC-S101.
- 3.4.5** Backwraps
- 3.4.5.1** Edges of ADEX EPS INSULATION that meet dissimilar substrates, terminations, wall openings, etc. shall be backwrapped.
- 3.4.5.2** Basecoat/mesh backwrap method
- a) Spread ADEX BASECOAT (mixed with Portland cement) over the end and onto the face of the board wide enough to adhere minimum 76mm (3") of mesh. Wrap the mesh around the board edge so it extends minimum 76mm (3") onto the opposite surface.
  - b) Allow the basecoat/mesh backwrap to dry prior to installation.
- 3.4.5.3** GD-CONTOUR BOARD method
- a) Pre-wrapped GD-CONTOUR BOARD shall be installed at the perimeter of walls and openings (this includes system terminations, where dissimilar substrates meet, at expansion joints, at doors and windows, etc.).
- b) See section 3.4.6 for details on the insulation board installation.
- 3.4.6** Insulation Boards
- 3.4.6.1** Apply ADEX BASECOAT adhesive as vertical ribbons onto the approved membrane on the wall using a 3/8" x 1/2" x 1-1/2" U-notched trowel.
- 3.4.6.2** ADEX EPS-GD INSULATION boards shall be placed horizontally on the walls starting with edge wrapped boards at the base of the wall. Apply firm pressure over the entire surface of the board to ensure complete contact of the adhesive to the substrate. Ensure the adhesive does not dry prior to installation of the insulation boards.
- 3.4.6.3** EPS Boards shall be butted tightly together to eliminate any thermal breaks. Care must be taken to prevent adhesive from getting between the joints of the ADEX EPS-GD INSULATION boards.
- 3.4.6.4** Gaps between insulation boards shall be packed with slivers of EPS foam or filled with an expanding spray-foam compatible with the insulation board.
- 3.4.6.5** Stagger vertical joints and interlock insulation boards at all inside and outside corners.
- 3.4.6.6** Stagger insulation board and sheathing board joints at least 150mm (6") apart from each other.
- 3.4.6.7** Where the adex-**RS** system meets dissimilar substrates and/or terminates (vertically) the ADEX EPS-GD INSULATION shall be backwrapped (as per paragraph 3.4.5 of this Section).
- 3.4.6.8** ADEX EPS-GD INSULATION boards shall be rasped to achieve a smooth even surface, create better adhesion, and remove possible ultra-violet damage and/or other surface pollutants.
- 3.4.6.9** The entire surface of the ADEX EPS-GD INSULATION boards shall be clean prior to the application of the ADEX BASECOAT and reinforcing mesh.
- 3.4.7** Aesthetic Details
- 3.4.7.1** V-grooves/Reveals shall be installed as per the construction documents (after the insulation boards have been rasped). Aesthetic details create visual enhancements, ease finish coat applications, and provide drip edges to soffit areas.

- 3.4.7.2 V-grooves/Reveals shall be completed using a hot-wire knife to ensure tight, crisp lines are maintained. The inset areas shall be finished with mesh and basecoat.
- 3.4.7.3 A minimum thickness of 19mm (3/4") of EPS insulation, between the substrate and base of any reveal, shall be maintained.
- 3.4.7.4 V-grooves/Reveals shall not be in alignment with insulation board joints or with the corners of openings.
- 3.4.8 Batten & Foam Details
  - 3.4.8.1 All battens made of expanded polystyrene (EPS) shall be installed by bonding them with ADEX BASECOAT adhesive, or with spray polyurethane such as Wind-lock's Foam-2-Foam, or by mechanically fastening them to the structure.
  - 3.4.8.2 Foam battens shall be locked to the ADEX EPS-GD INSULATION by embedding the mesh "wings" of the batten into ADEX BASECOAT.
  - 3.4.8.3 All batten details extending more than 50mm (2") beyond the basecoat must have an outward-facing slope (minimum of 22° degrees) to prevent moisture from accumulating on them.
  - 3.4.8.4 All cornice and parapet details shall be cap-flashed regardless of slope.
- 3.4.9 Basecoat & Reinforcing Mesh
  - 3.4.9.1 Apply ADEX BASECOAT over the ADEX EPS-GD INSULATION surface to a uniform thickness of approximately 1.6 mm (1/16"). Work horizontally or vertically in strips of 1016mm (40"), and immediately embed Adex STANDARD MESH into the wet basecoat.
  - 3.4.9.2 Install an additional 300mm (12") long piece of STARTER/DETAIL MESH (at a 45°-degree angle) at the corners of all wall openings.
  - 3.4.9.3 STANDARD MESH shall be double lapped not less than 200mm (8") at all corners and overlapped not less than 63mm (2.5") at mesh joints. Avoid wrinkles from forming in the mesh.
  - 3.4.9.4 ARMOUR MESH is advised in high traffic areas (Optional).
    - a) Install ARMOUR MESH as per locations noted in the construction drawings.
    - b) Apply ADEX BASECOAT to the surface of the insulation boards to a thickness of 2.4mm (3/32") and embed ARMOUR MESH (vertical application is preferred). Smooth the surface until the mesh is fully embedded.
    - c) ARMOUR MESH shall be abutted and not lapped.
    - d) The ARMOUR MESH shall be installed to heights indicated in the plans.
    - e) All layers of ARMOUR MESH shall be covered with a layer of STANDARD MESH.
- 3.4.9.5 CORNER MESH is recommended at all major inside/outside corners (Optional).
  - a) Install CORNER MESH on exposed interior/exterior corners as noted in the construction documents.
- 3.4.9.6 Allow the basecoat to dry before applying the primer and finish coat (24-hours).
- 3.4.10 Point-Impact Resistant Basecoat (Optional)
  - 3.4.10.1 First Coat - GRAPHEXCOAT-A
    - a) Using a flat-edge metal trowel, apply GRAPHEXCOAT-A to the surface of the Adex BASE COAT at a thickness between 3/32" and 1/8".
    - b) Holding your trowel at a low-angle, smooth out the basecoat, using the largest aggregate in the GRAPHEXCOAT-A to assist with achieving the proper thickness.
    - c) Allow the GRAPHEXCOAT-A to dry before applying the secondary GRAPHEXCOAT-B layer.
  - 3.4.10.2 Second Coat- GRAPHEXCOAT-B
    - a) Inspect the GRAPHEXCOAT-A installation and rasp down any irregular surfaces or high spots.
    - b) With a flat-edge metal trowel, apply a 1.6mm (1/16") uniform layer of GRAPHEXCOAT-B over the entire first coat application and smooth the surface. Take care to fill any voids left behind by the GRAPHEXCOAT-A installation.
    - c) Once dry, install additional skim coat layers of GRAPHEXCOAT-B as required.
  - 3.4.10.3 Allow the GRAPHEXCOAT-B to dry before applying any additional basecoat layers or continuing on to the primer and finish coat (24-hours).
  - 3.4.10.4 The final dry-film thickness of GRAPHEXCOAT (both layers) shall be no less than 2.5mm (3/32").

### 3.4.11 Primer

- 3.4.11.1 Apply an even coat of PRIMEX PRIMER (tinted to the same colour as the finish coat) with a good-quality paintbrush, 10mm (3/8") nap roller, or sprayer.
- 3.4.11.2 Allow PRIMEX PRIMER to dry before commencing with the Finish Coat.

### 3.4.12 Finish Coat

- 3.4.12.1 Trowel-apply a tight coat of Adex Finish Coat, texture [see [www.adex.ca](http://www.adex.ca) or Adex Specification Binder] to a thickness not greater than the largest aggregate. Apply the finish coat with a stainless steel trowel in a continuous fashion, maintaining a wet edge. Levelling and texturing shall take place in one operation to give the Adex Finish Coat a uniform appearance.
- 3.4.12.2 Avoid applications in direct sunlight.
- 3.4.12.3 Avoid applying finish coat at locations where caulking will be installed.
- 3.4.12.4 Weather conditions will be a factor in the application and drying time of the Finish Coat.

### 3.4.13 Caulking

- 3.4.13.1 Refer to Section 07 90 00, Sealant.
- 3.4.13.2 Caulking shall be installed in a timely manner. Protect open joints from water intrusion during the construction period with backer rod until permanently sealed.

## 3.5 PROTECTION

- 3.5.1 Ensure that the general contractor protects all work against moisture infiltration and other damages by installing the necessary flashing and caulking in a timely manner.
- 3.5.2 Provide protection against dirt, moisture, high humidity, and freezing temperatures until materials are fully dry.

## 3.6 CLEAN UP

- 3.6.1 After completion, remove waste and leftover materials (used in this Section) from the job site.
- 3.6.2 Clean all adjacent materials and surfaces, and repair any defects to this application or any defects to any other work caused by this application, all to the approval of the consultant.

**ALL REQUESTS FOR APPLICATION PROCEDURAL CHANGES MUST BE AUTHORIZED IN WRITING BY ADEX SYSTEMS INC.**

#### CORPORATE SALES CENTER

7911, Marco Polo  
Montreal (Quebec) Canada H1E 1N8  
[www.adex.ca](http://www.adex.ca)  
P 514-648-1213 | F 514-648-9597  
September 2024

Information in this document contains the current recommendations for the installation of the adex-**RS** system. It is only provided as a guide and is subject to modifications at any time without notice. ADEX Systems Inc. reserves the right to make any modification according to technological progress. Specialised designers, architects, engineers or other professionals that choose to make any use of this information bear the complete responsibility, whatever it be, direct or indirect, that could follow from such use. ADEX Systems Inc. does not bear any responsibility that could give way to damages, defaults, defects, deficiencies, prejudices, loss or decrease of profit, be they direct or indirect, resulting from such use of this information by specialised designers, architects, engineers or other professionals. Please refer to [www.adex.ca](http://www.adex.ca) for the latest version of this document.

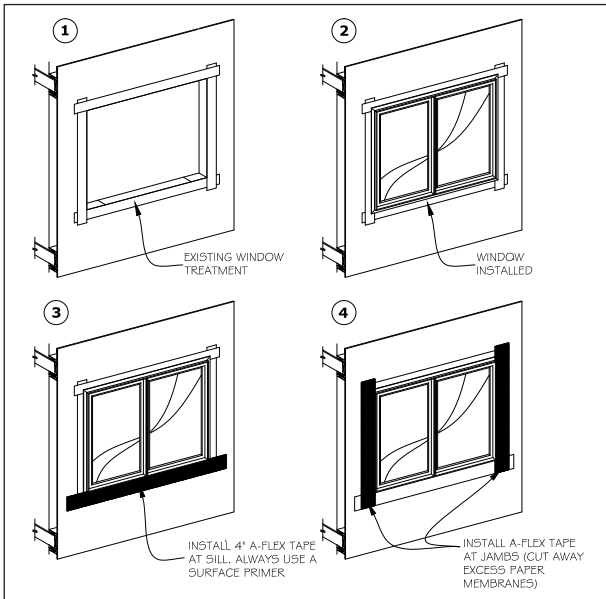

**WINDOW TREATMENT - PART 1**

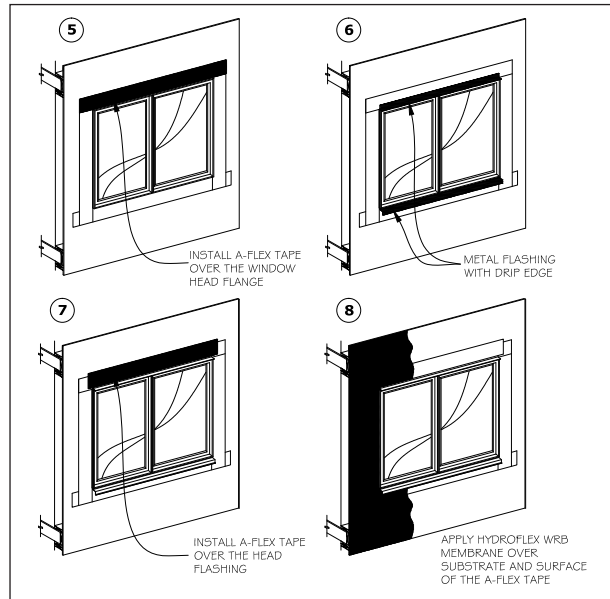

**WINDOW TREATMENT - PART 2**

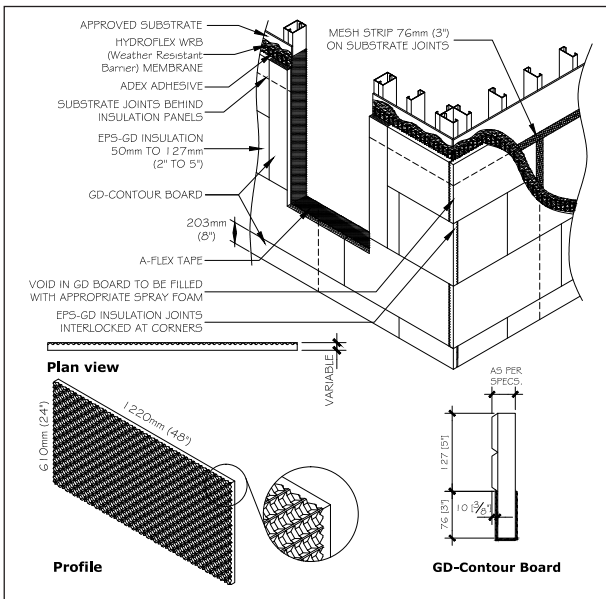

**INSULATION INSTALLATION - METHOD 1**

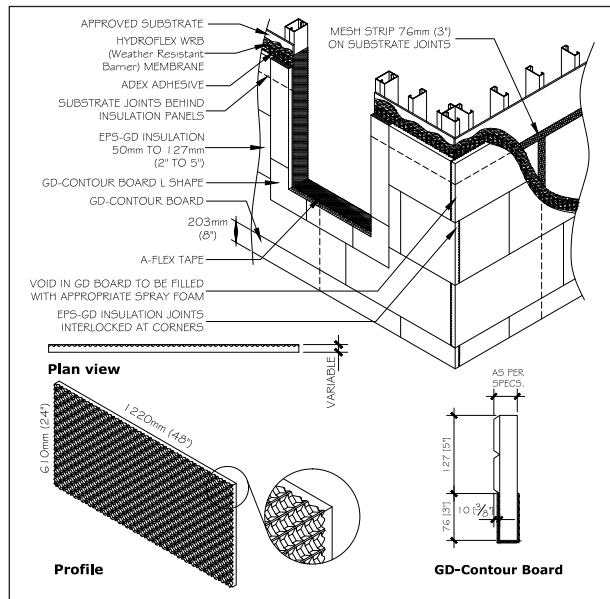

**INSULATION INSTALLATION - METHOD 2**

Information in this document contains the current recommendations for the installation of the adex-RS system. It is only provided as a guide and is subject to modifications at any time without notice. ADEX Systems Inc. reserves the right to make any modification according to technological progress. Specialised designers, architects, engineers or other professionals that choose to make any use of this information bear the complete responsibility, whatever it be, direct or indirect, that could follow from such use. ADEX Systems Inc. does not bear any responsibility that could give way to damages, defaults, defects, deficiencies, prejudices, loss or decrease of profit, be they direct or indirect, resulting from such use of this information by specialised designers, architects, engineers or other professionals. Please refer to [www.adex.ca](http://www.adex.ca) for the latest version of this document.

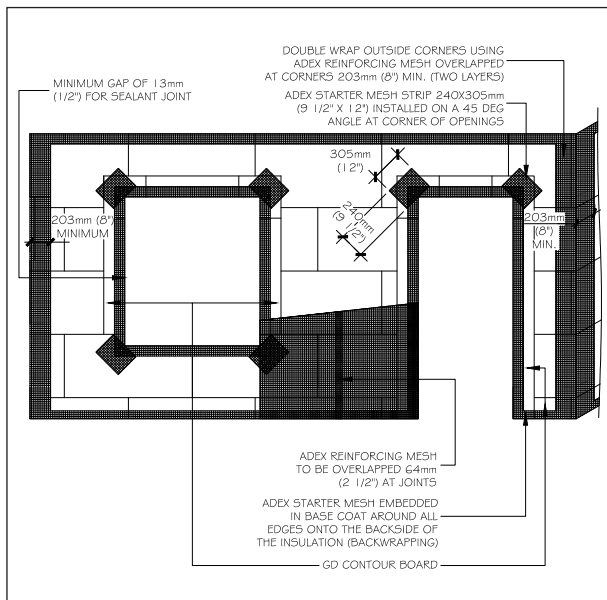

**REINFORCING MESH INSTALLATION**

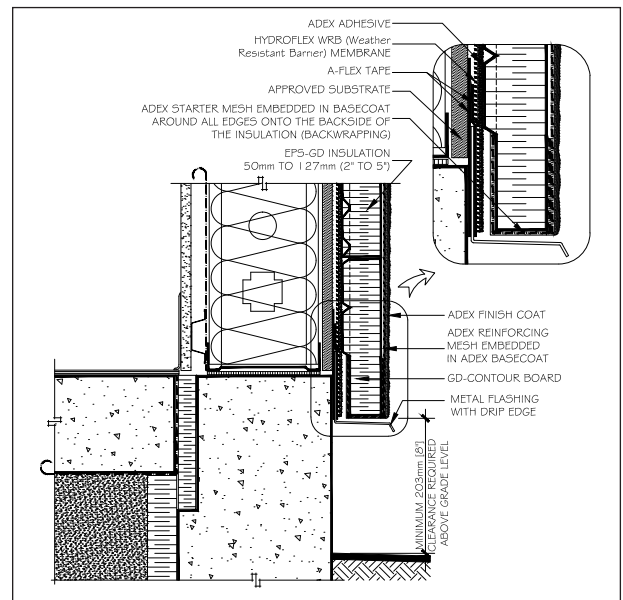

**TERMINATION AT GRADE - METHOD A**

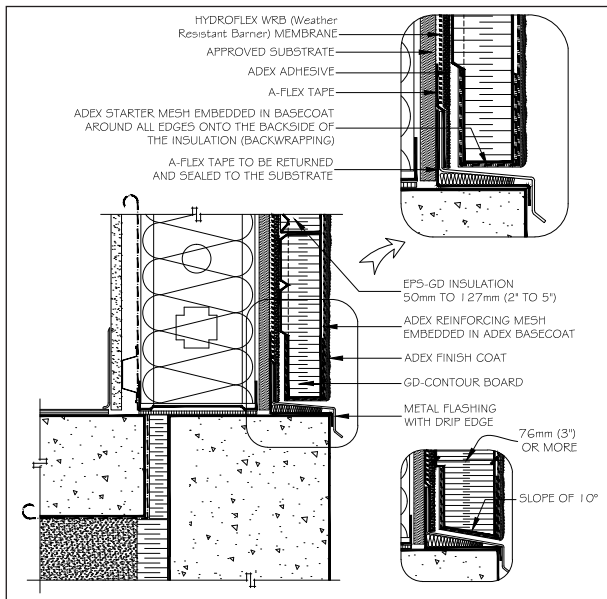

**TERMINATION AT GRADE - METHOD B**

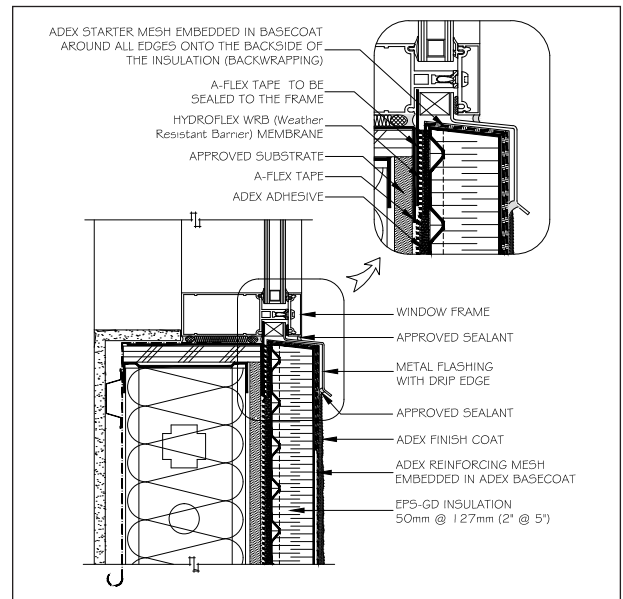

**WINDOW SILL (ALUMINUM WINDOW)**

Information in this document contains the current recommendations for the installation of the adex-RS system. It is only provided as a guide and is subject to modifications at any time without notice. ADEX Systems Inc. reserves the right to make any modification according to technological progress. Specialised designers, architects, engineers or other professionals that choose to make any use of this information bear the complete responsibility, whatever it be, direct or indirect, that could follow from such use. ADEX Systems Inc. does not bear any responsibility that could give way to damages, defaults, defects, deficiencies, prejudices, loss or decrease of profit, be they direct or indirect, resulting from such use of this information by specialised designers, architects, engineers or other professionals. Please refer to [www.adex.ca](http://www.adex.ca) for the latest version of this document.

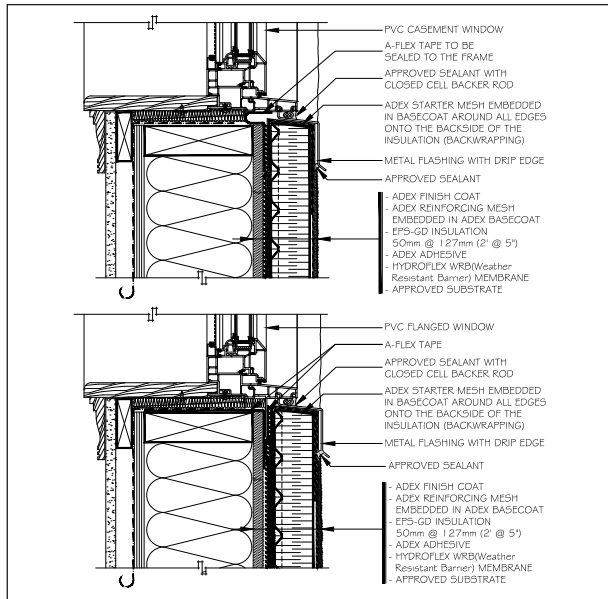

WINDOW SILL (PVC WINDOW)

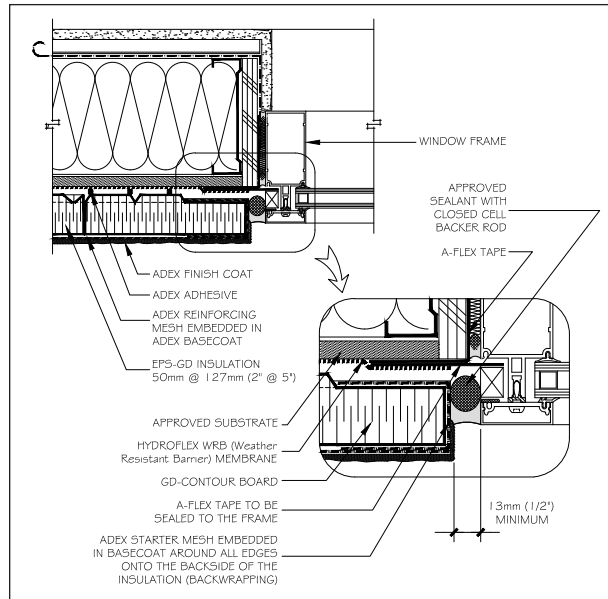

WINDOW JAMB (ALUMINUM WINDOW)

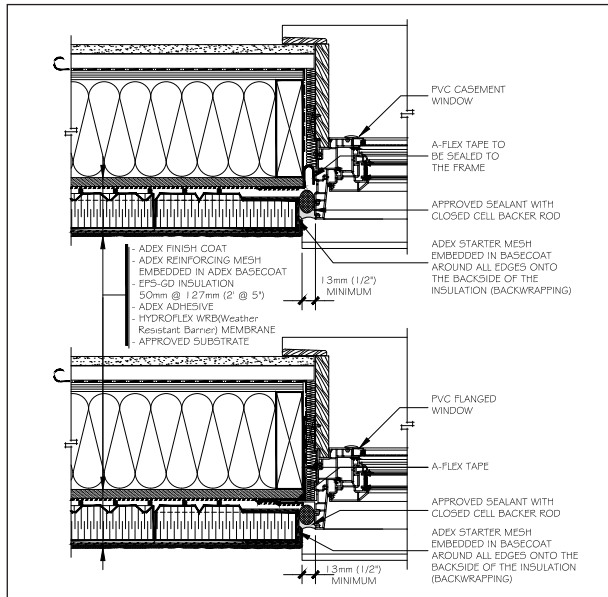

WINDOW JAMB (PVC WINDOW)

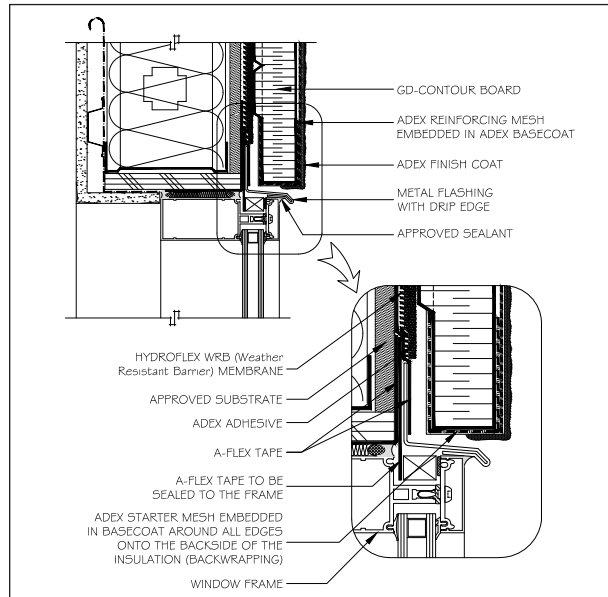

WINDOW HEAD (ALUMINUM WINDOW)

Information in this document contains the current recommendations for the installation of the adex-RS system. It is only provided as a guide and is subject to modifications at any time without notice. ADEX Systems Inc. reserves the right to make any modification according to technological progress. Specialised designers, architects, engineers or other professionals that choose to make any use of this information bear the complete responsibility, whatever it be, direct or indirect, that could follow from such use. ADEX Systems Inc. does not bear any responsibility that could give way to damages, defaults, defects, deficiencies, prejudices, loss or decrease of profit, be they direct or indirect, resulting from such use of this information by specialised designers, architects, engineers or other professionals. Please refer to [www.adex.ca](http://www.adex.ca) for the latest version of this document.

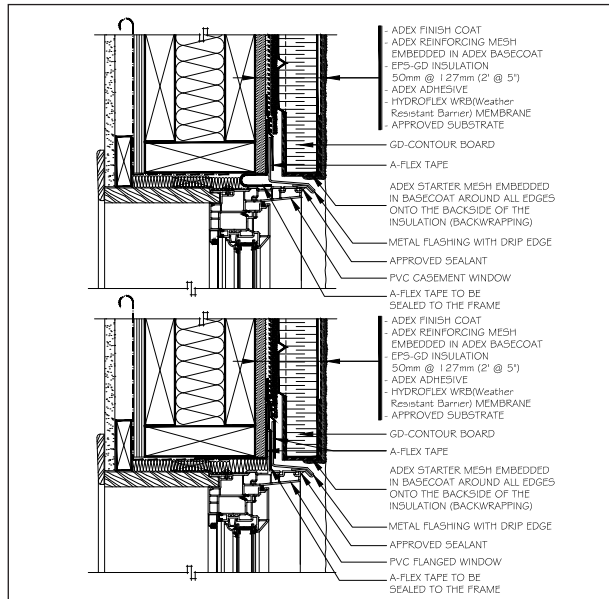

WINDOW HEAD (PVC WINDOW)

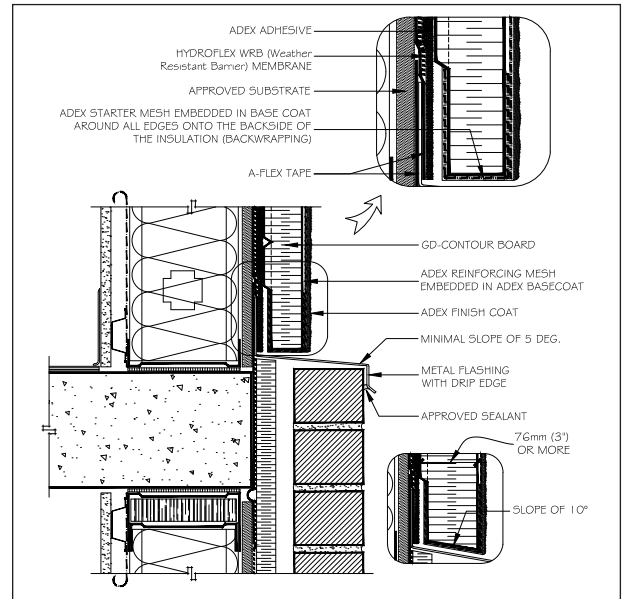

HORIZONTAL JUNCTION

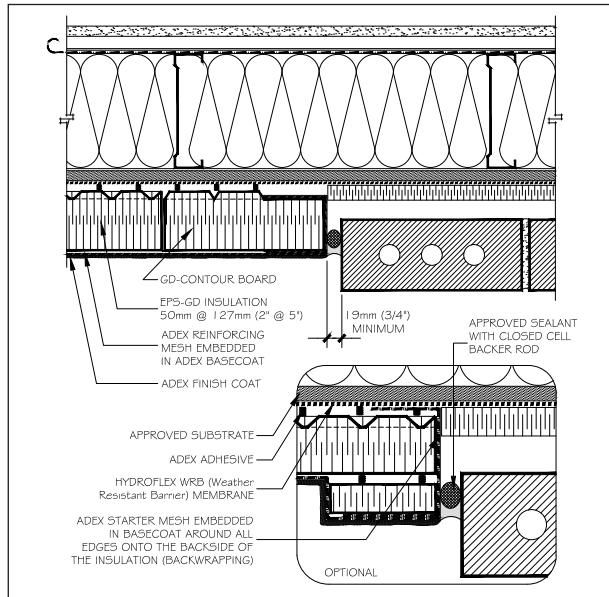

VERTICAL JUNCTION

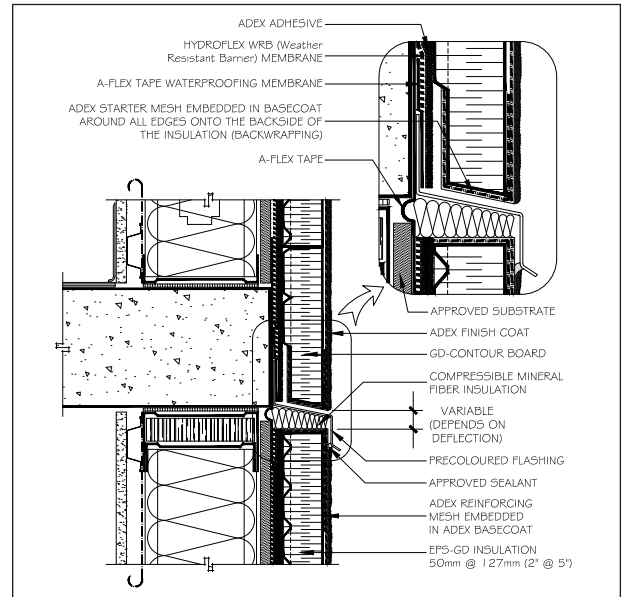

HORIZONTAL CONTROL JOINT - METHOD A

Information in this document contains the current recommendations for the installation of the adex-RS system. It is only provided as a guide and is subject to modifications at any time without notice. ADEX Systems Inc. reserves the right to make any modification according to technological progress. Specialised designers, architects, engineers or other professionals that choose to make any use of this information bear the complete responsibility, whatever it be, direct or indirect, that could follow from such use. ADEX Systems Inc. does not bear any responsibility that could give way to damages, defaults, defects, deficiencies, prejudices, loss or decrease of profit, be they direct or indirect, resulting from such use of this information by specialised designers, architects, engineers or other professionals. Please refer to [www.adex.ca](http://www.adex.ca) for the latest version of this document.

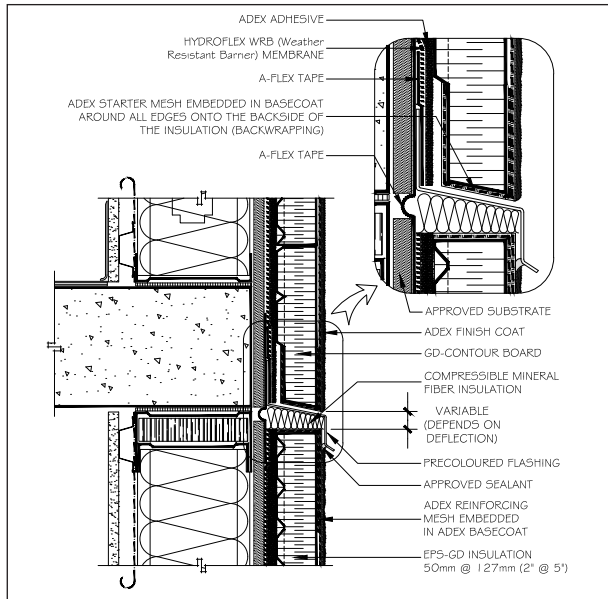

**HORIZONTAL CONTROL JOINT - METHOD B**

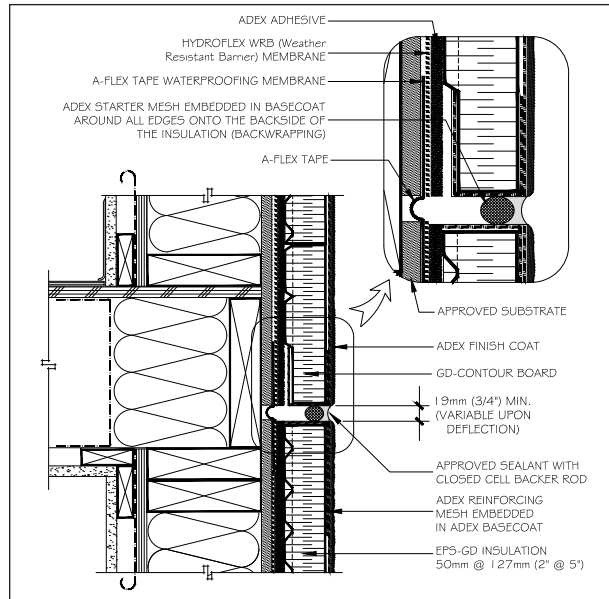

**HORIZONTAL CONTROL JOINT - METHOD C**

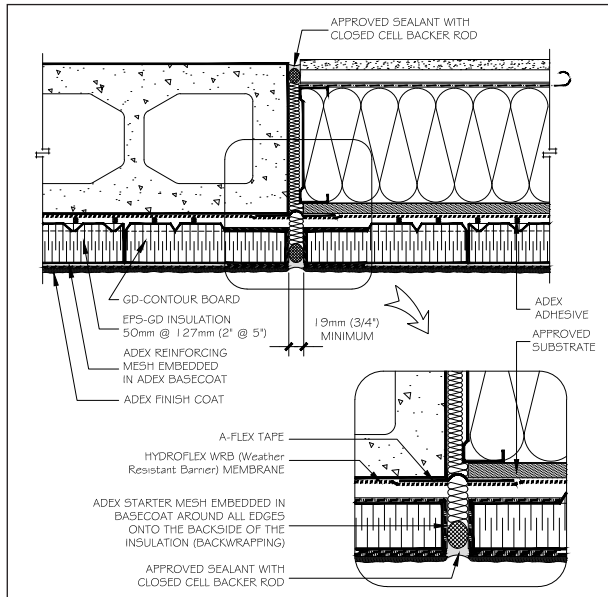

**VERTICAL EXPANSION JOINT**

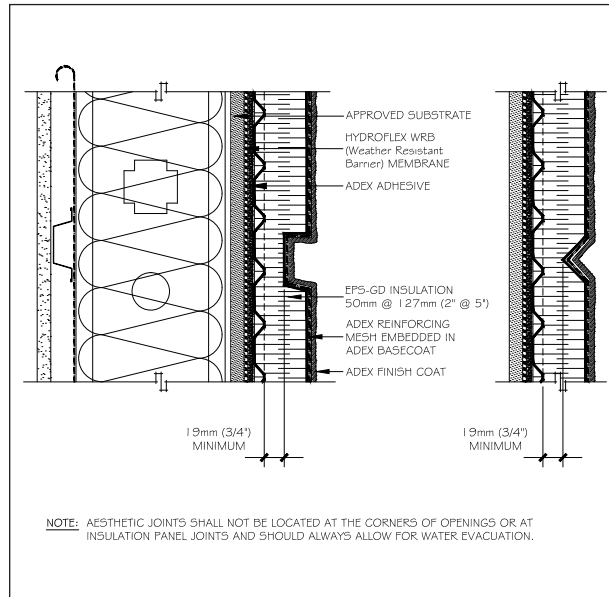

**AESTHETIC JOINT**

Information in this document contains the current recommendations for the installation of the adex-**RS** system. It is only provided as a guide and is subject to modifications at any time without notice. ADEX Systems Inc. reserves the right to make any modification according to technological progress. Specialised designers, architects, engineers or other professionals that choose to make any use of this information bear the complete responsibility, whatever it be, direct or indirect, that could follow from such use. ADEX Systems Inc. does not bear any responsibility that could give way to damages, defaults, defects, deficiencies, prejudices, loss or decrease of profit, be they direct or indirect, resulting from such use of this information by specialised designers, architects, engineers or other professionals. Please refer to [www.adex.ca](http://www.adex.ca) for the latest version of this document.

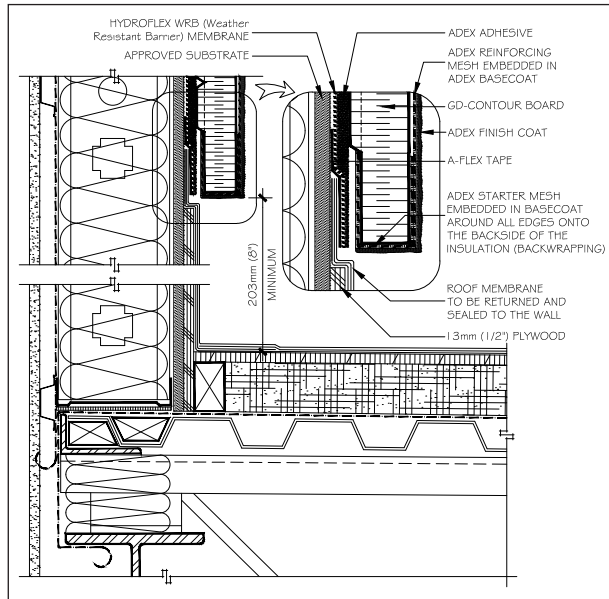

WALL/ROOF JUNCTION - FLAT ROOF

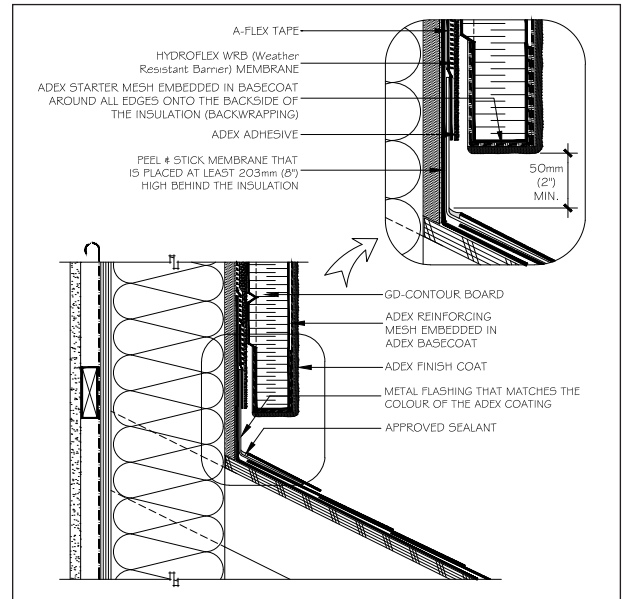

WALL/ROOF JUNCTION - SLOPED ROOF

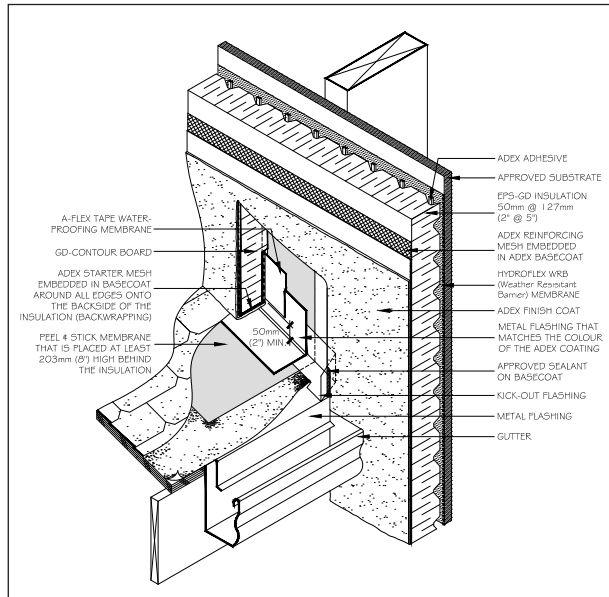

WALL/ROOF JUNCTION - ISOMETRY

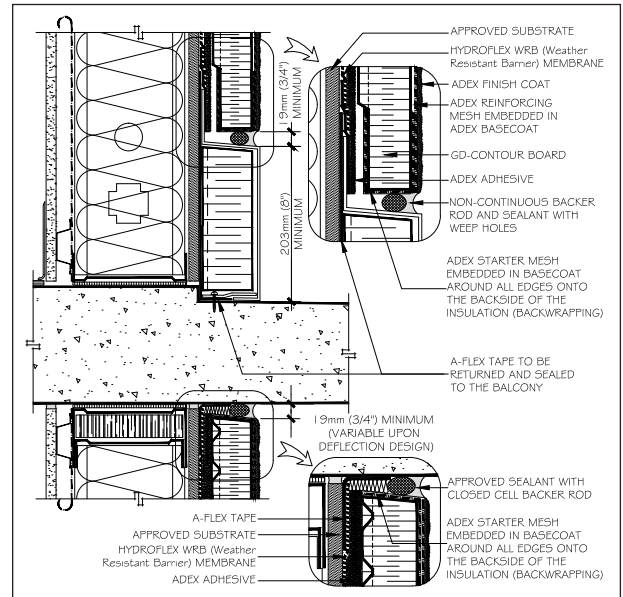

BALCONY JUNCTION

Information in this document contains the current recommendations for the installation of the adex-RS system. It is only provided as a guide and is subject to modifications at any time without notice. ADEX Systems Inc. reserves the right to make any modification according to technological progress. Specialised designers, architects, engineers or other professionals that choose to make any use of this information bear the complete responsibility, whatever it be, direct or indirect, that could follow from such use. ADEX Systems Inc. does not bear any responsibility that could give way to damages, defaults, defects, deficiencies, prejudices, loss or decrease of profit, be they direct or indirect, resulting from such use of this information by specialised designers, architects, engineers or other professionals. Please refer to [www.adex.ca](http://www.adex.ca) for the latest version of this document.

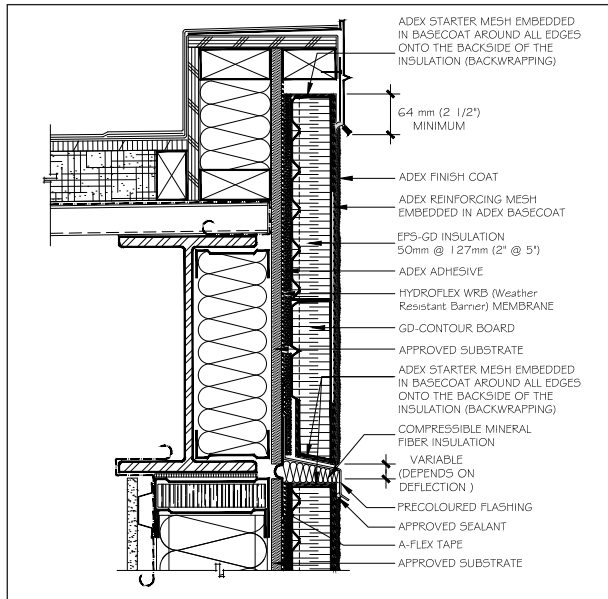

PARAPET

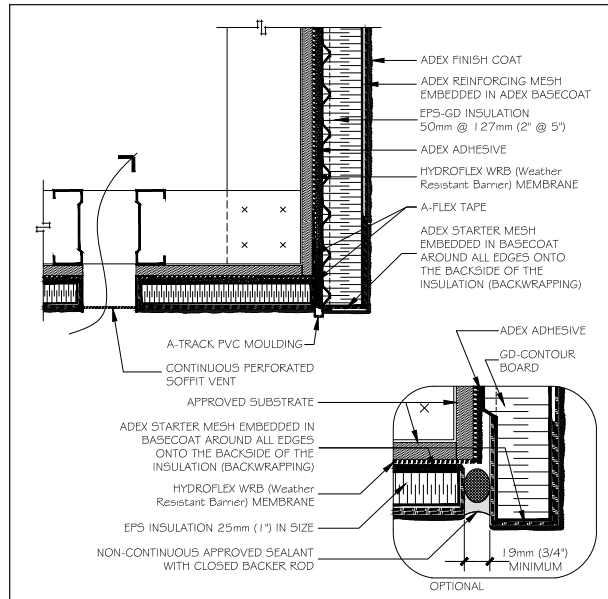

SOFFIT

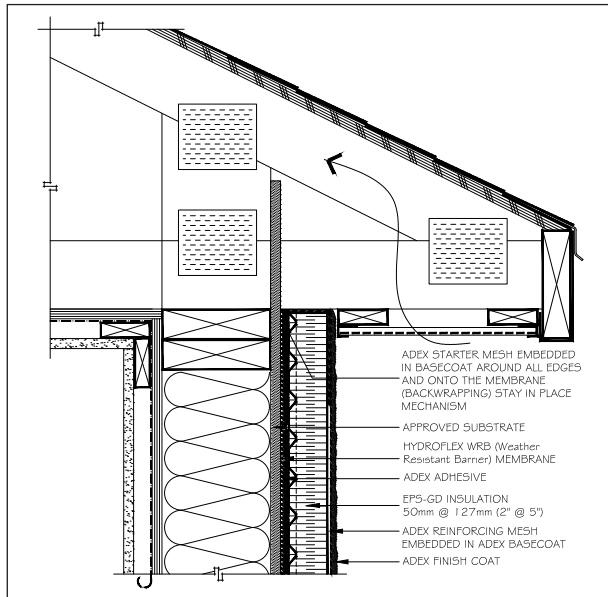

EAVE SOFFIT JUNCTION - SLOPED ROOF

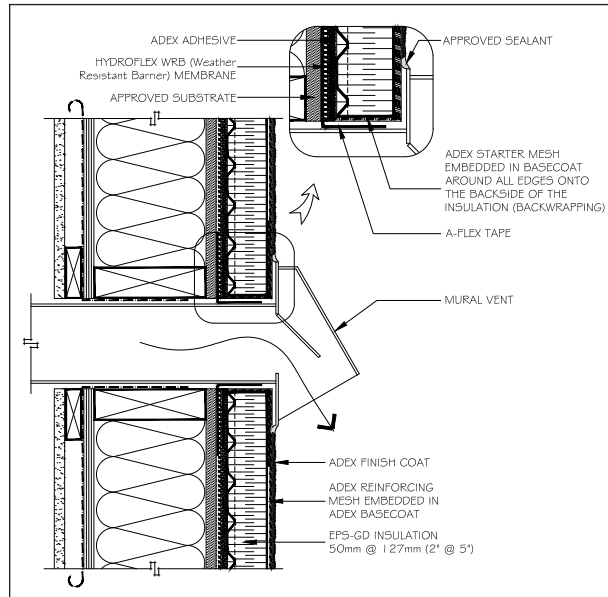

WALL PENETRATIONS

Information in this document contains the current recommendations for the installation of the adex-RS system. It is only provided as a guide and is subject to modifications at any time without notice. ADEX Systems Inc. reserves the right to make any modification according to technological progress. Specialised designers, architects, engineers or other professionals that choose to make any use of this information bear the complete responsibility, whatever it be, direct or indirect, that could follow from such use. ADEX Systems Inc. does not bear any responsibility that could give way to damages, defaults, defects, deficiencies, prejudices, loss or decrease of profit, be they direct or indirect, resulting from such use of this information by specialised designers, architects, engineers or other professionals. Please refer to [www.adex.ca](http://www.adex.ca) for the latest version of this document.

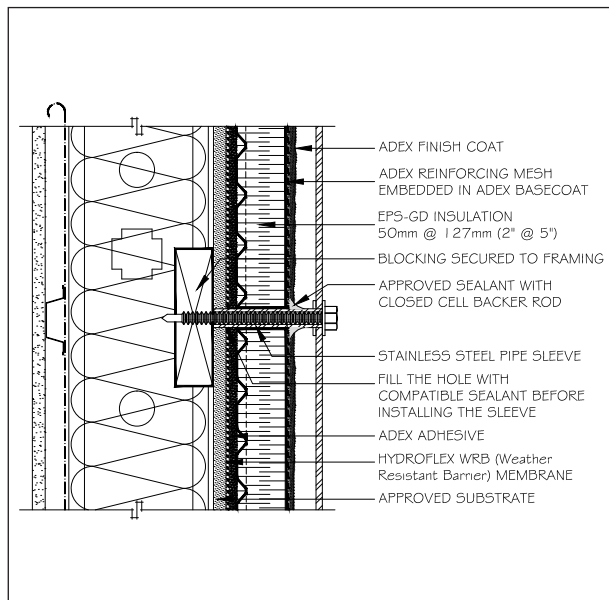

**ACCESSORIES ATTACHMENT**

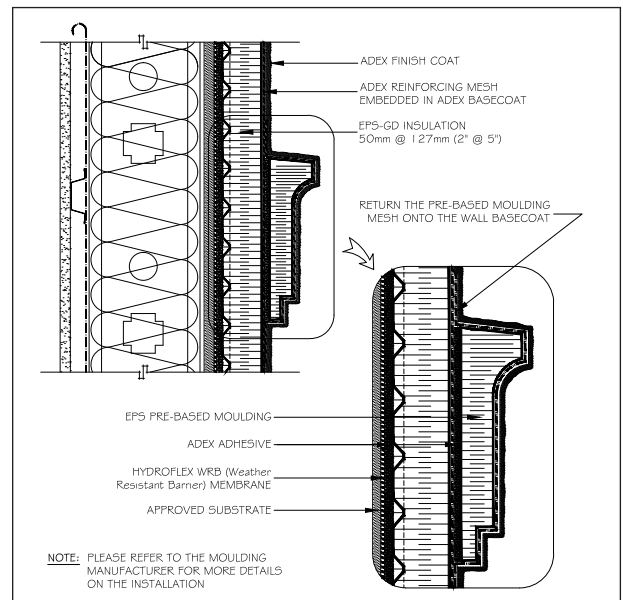

**DECORATIVE MOULDING**

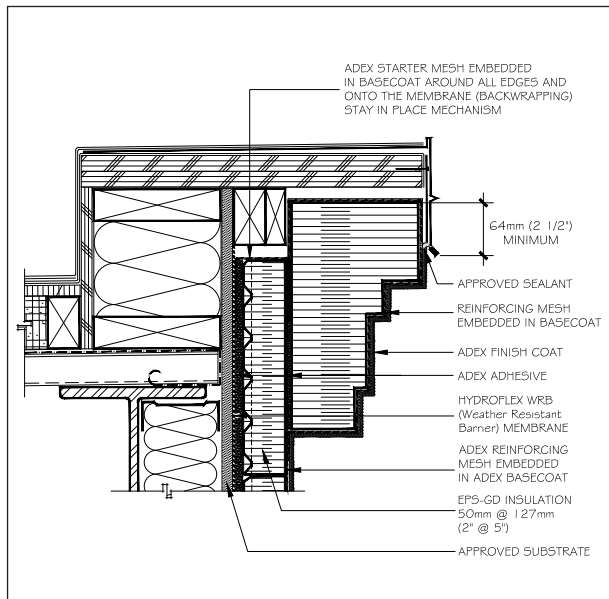

**PARAPET MOULDING**

Information in this document contains the current recommendations for the installation of the adex-RS system. It is only provided as a guide and is subject to modifications at any time without notice. ADEX Systems Inc. reserves the right to make any modification according to technological progress. Specialised designers, architects, engineers or other professionals that choose to make any use of this information bear the complete responsibility, whatever it be, direct or indirect, that could follow from such use. ADEX Systems Inc. does not bear any responsibility that could give way to damages, defaults, defects, deficiencies, prejudices, loss or decrease of profit, be they direct or indirect, resulting from such use of this information by specialised designers, architects, engineers or other professionals. Please refer to [www.adex.ca](http://www.adex.ca) for the latest version of this document.